

Model: CD-DPC

Rating: Class 150 ~2500



Design feature:

- Applications for Hydraulic, Chemical, Steam, Oil/ Gas, Oxygen, Vacuum.
- Reduced dimensions and weights.
- Installation in any Position Even With Downward Flow.
- Suitable For Working as Over press Valve, Vacuum Breaker Valve, Bottom Valve.
- Low Pressure Drops Reduce energy cost.
- Lapped Body Seat & Disc Sealing Face.
- Body with uninterrupted gasket surface.
- Disc Integral with Shock Bumpers.
- Metal-to-metal Seat is standard, Soft Seat is option.
- Valve Body Seat & Disc Sealing Face upon request.
- End Connections:
Wafer; Lug ; RF Flange/ RTJ Flange.
- DIN 50049-3.1 Certificate Available

Specifications:

- Flow bore: full port.
- Rating:
ANSI Class 150/ 300/ 600/ 900/ 1500/ 2500
- Temperature: -20°F ~ 800°F
- Materials:
ASTM A351 CF8M, CF8, CF3M
ASTM A216 WCB
- Size range:
Class 150 & 300 2"~48"
Class 600 & 900 2"~24"
Class 1500 2"~16"
Class 2500 2"~12"

Standard:

- Basic Design to ASME B16.34
- Flange dimension according to ANSI B16.5
- Flange Dimension to ANSI B16.5, B16.47(above 24").
- Face-to-face meets to API 594.
- Inspection & testing according to API 598, API 6D

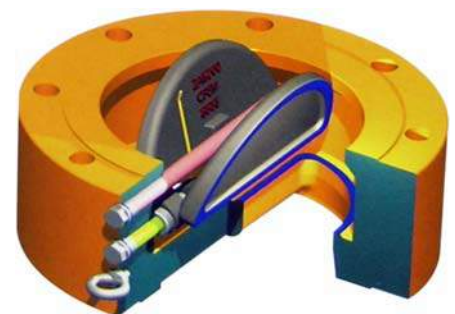
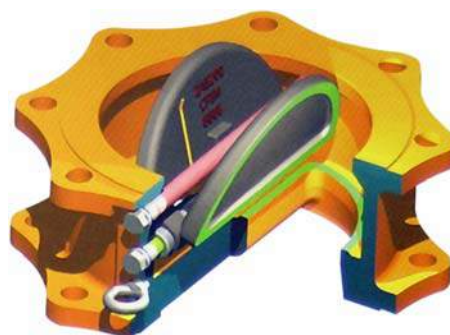
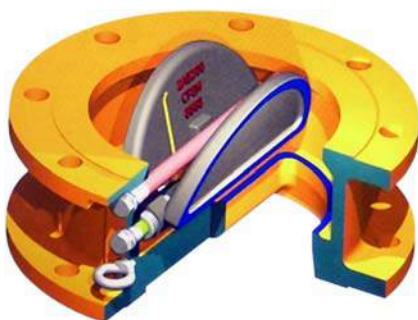

CV FORMULA & CV, KV VALUES

* Cv Pressure Drop Formula

**Based upon ISA S75.01-1985
For turbulent flow**

For Liquids

$$Q = C_v * (\Delta P / G_f)^{1/2}$$

Q max of R

$$0.7 * C_v * (P_1 - F_f P_v) / G_f^{1/2}$$

vaporising liquid

$$W = 63.3 * C_v * (\Delta P * \alpha_1)^{1/2}$$

For Gases & Vapors

$$Q = 1360 * C_v * P_1 * Y * [X / (G_g * T_1 * Z)]^{1/2}$$

$$W = 19.3 * C_v * P_1 * Y * [(X * M) / (T_1 * Z)]^{1/2}$$

$$W = 19.3 * C_v * P_1 * Y * [(X * M) / (T_1 * Z)]^{1/2}$$

$$[(X * M) / (T_1 * Z)]^{1/2}$$

Q = Flow

Liquid = U.S. gall/minute

Gas = standard ft³/hour

C_v = Valve co-efficient

ΔP = (P₁-P₂) Pressure drop psi

P₁ = Inlet Pressure psi

P₂ = Outlet Pressure psi

G_f = Specific Gravity of fluid,
e.g. water = 1; @60°F; 1 atm

G_g = Specific Gravity of gas,
e.g. gas = 1; @60°F; 1 atm

T₁ = Absolute inlet temperature

W = Flow lbs/hour

Y = Expansion factor
(limits between 1 & 0.67)

X = Ratio of Pressure Drop ΔP
to absolute inlet Pressure 1P

Z = Gas compressibility factor
(=1 for sn ideal gas)

M = Molecular weight

α₁ = Specific weight, upstream
conditions (lb/ft³)

F_r = Liquid critical pressure
ratio factor

$$F_r = 0.96 - 0.28 (P_v / P_c)^{1/2}$$

P_v = Absolute vapor pressure
of liquid at inlet
temperature in psi

P_c = Absolute thermodynamic
critical pressure

*Cv & Kv Values (Cv=1.17xKv)

Size	Cv	Kv
2"	54.5	46.6
2-1/2"	84.6	72.3
3"	137.5	117.5
4"	283.1	242.0
5"	491.3	419.9
6"	812.1	694.1
8"	1499.5	1281.6
10"	2587.3	2211.4
12"	4214.8	3602.3
14"	5547.3	4741.3
16"	7549.7	6452.7
18"	10548.7	9016.0
20"	13325.6	11390.0
22"	20150.0	17222.0
24"	21500.0	18376.0
26"	26400.0	22564.0
28"	29900.0	25555.0
30"	38400.0	32821.0
32"	46500.0	39744.0
36"	62000.0	52992.0
40"	84500.0	72222.0
42"	91300.0	78034.0
44"	114800.0	98120.0
48"	145100.0	124017.0

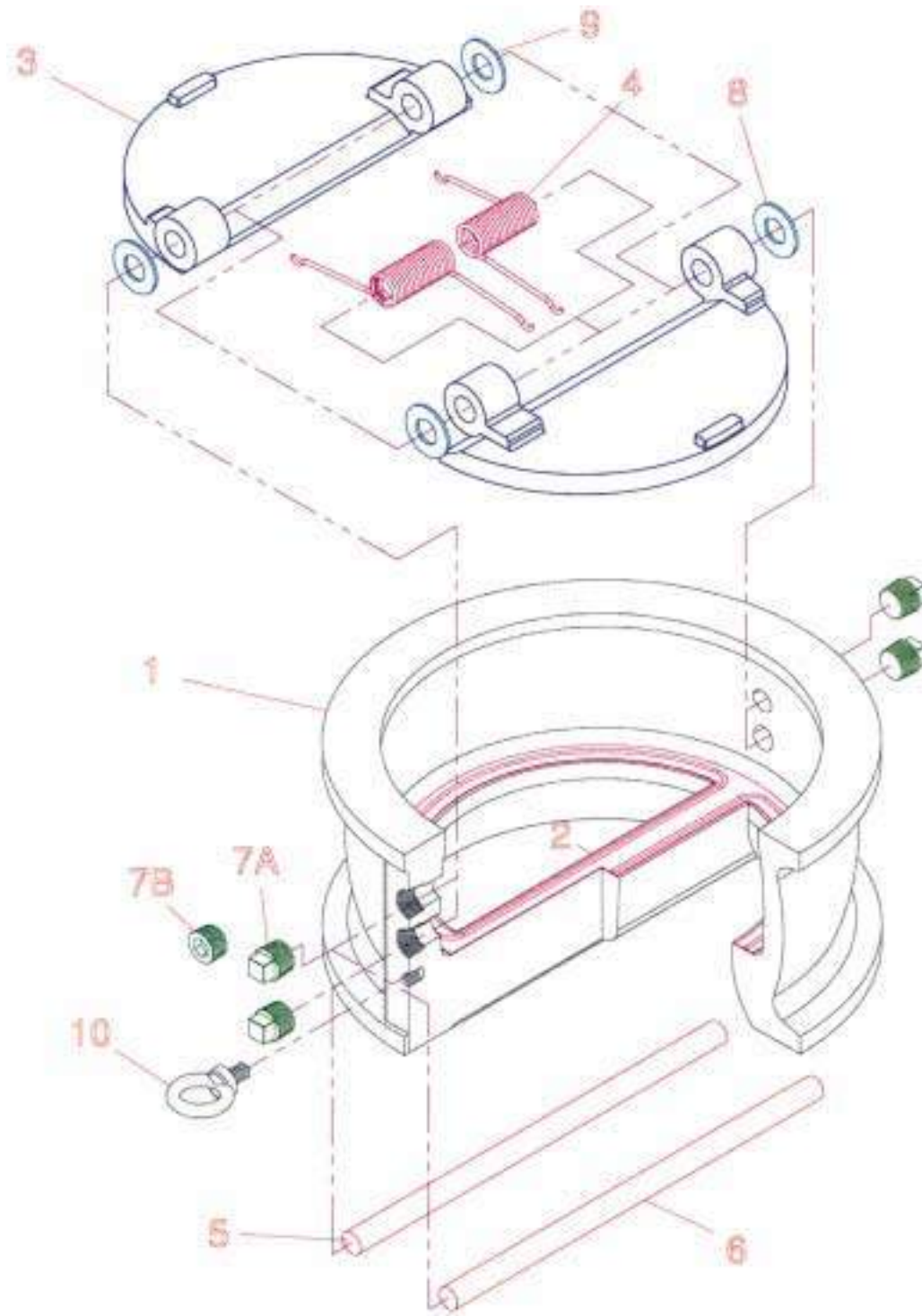

MATERIALS LIST:

NO	PARTS NAME	MATERIAL
1	BODY	WCB, WC6, WC9, LCB, A351 CF8/ CF3/ CF8M / CF3M, upon request.
2	SEAT	13Cr, SS304, SS316, MONEL, ALLOY-20, upon request.
3	PLATE	A216 WCB, A351 CF8/ CF3/ CF8M / CF3M, upon request.
4	SPRING	INCONEL-750/ 600, SS304, SS304L, SS316, SS316L, upon request.
5	HINGE PIN	A182 F304L, 2CR13
6	STOP PIN	A182 F304L
7A & 7B	RETAINER	CARBON STEEL
8	BODY BEARING	A182 F304L
9	SPRING HOLDER	A182 F304L / A105
10	EYE BOLT	CARBON STEEL

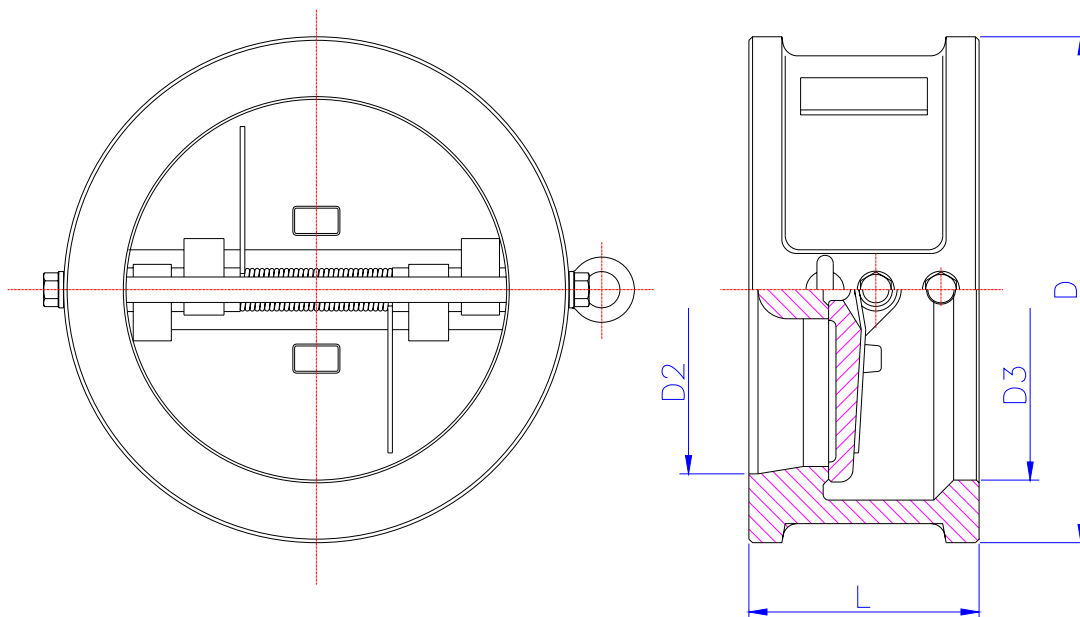

Dimensions List:

Class 150 (PN20)																				
Size	2"	2.5"	3"	4"	5"	6"	8"	10"	12"	14"	16"	18"	20"	24"	28"	30"	32"	36"	42"	48"
DN	50	65	80	100	125	150	200	250	300	350	400	450	500	600	700	750	800	900	1050	1200
L	60	67	73	73	86	98	127	146	181	184	191	203	219	222	305	305	305	368	432	524
D	103	122	135	173	195	220	277	337	407	448	512	547	604	715	773	824	878	983	1142	1302
D3	56	73	88	108	132	160	210	266	310	355	405	455	505	605	700	750	800	910	1055	1205
D2	51	65	80	102	127	152	203	254	305	350	400	450	500	600	700	746	796	898	1050	1200
Wt(kg)	2	3	4	6	8	13	25	39	54	80	117	138	163	331	380	425	560	640	960	1400

Class 300 (PN50)																				
Size	2"	2.5"	3"	4"	5"	6"	8"	10"	12"	14"	16"	18"	20"	24"	30"	36"	42"	48"		
DN	50	65	80	100	125	150	200	250	300	350	400	450	500	600	750	900	1050	1200		
L	60	67	73	73	86	98	127	146	181	222	232	264	292	318	368	483	568	629		
D	110	128	147	179	214	249	305	359	420	483	537	594	652	772	882	1044	1196	1365		
D3	58	73	88	108	132	160	210	266	310	355	405	455	505	608	740	880	1045	1190		
D2	51	65	80	102	127	152	203	254	305	350	400	450	500	600	735	873	1035	1179		
Wt(kg)	3	4	6	8	15	18	31	51	77	117	190	200	265	410	660	1020	1540	2260		

Class 600 (PN110)															
Size	2"	2.5"	3"	4"	5"	6"	8"	10"	12"	14"	16"	18"	20"	24"	
DN	50	65	80	100	125	150	200	250	300	350	400	450	500	600	
L	60	67	73	79	105	136	165	213	229	273	305	362	368	438	
D	110	128	147	191	239	264	318	398	455	490	562	610	680	786	
D3	58	73	88	108	136	162	212	266	312	355	400	450	500	600	
D2	51	65	80	102	127	152	200	250	305	337	387	438	489	591	
Wt(kg)	4	5	8	11	20	26	55	95	140	223	360	395	518	836	

Class 900 (PN150)															
Size	2"	2.5"	3"	4"	5"	6"	8"	10"	12"	14"	16"	18"	20"	24"	
DN	50	65	80	100	125	150	200	250	300	350	400	450	500	600	
L	70	83	83	102	110	159	206	241	292	356	384	451	451	495	
D	140	162	165	204	245	286	356	432	495	518	572	635	695	835	
D3	58	73	90	108	136	162	212	266	312	355	400	450	496	600	
D2	51	65	80	102	127	150	200	250	305	337	387	438	487	591	
Wt(kg)	8	11	14	20	30	42	84	145	220	350	470	605	820	1050	

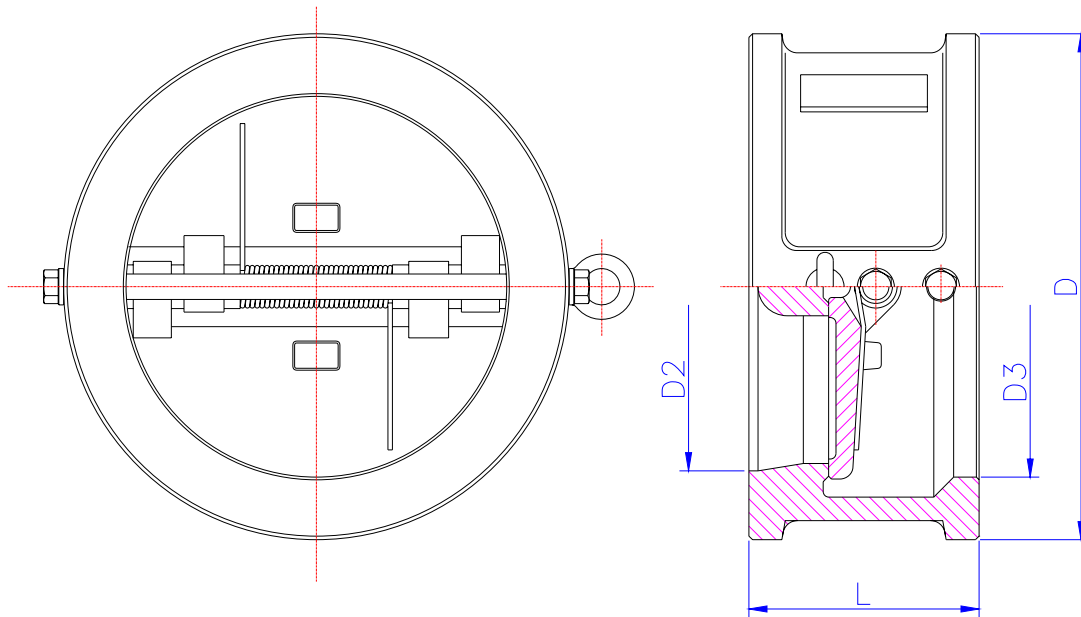

Class 1500 (PN260)											
Size	2"	2.5"	3"	4"	5"	6"	8"	10"	12"	14"	16"
DN	50	65	80	100	125	150	200	250	300	350	400
L	70	83	83	102	110	159	206	248	305	356	384
D	140	162	172	207	252	280	350	433	518	576	639
D3	58	73	90	108	136	162	212	266	312	355	400
D2	51	65	80	102	127	150	200	254	305	337	387
Wt(kg)	8	11	19	26	51	68	130	210	384	550	635

Class 2500 (PN 420)										
Size	2"	2.5"	3"	4"	5"	6"	8"	10"	12"	
DN	50	65	80	100	125	150	200	250	300	
L	70	83	86	105	110	159	206	254	305	
D	143	166	194	232	277	315	385	474	547	
D3	48	58	68	94	106	162	186	232	272	
D2	42	52	62	88	100	150	180	225	266	
Wt(kg)	10	18	26	40	59	90	150	240	440	

Version: 20051213



DIE ERSTE INDUSTRY CO., LTD

5F-1, No.936, Sec4, Wen-Sin Road, Taichung, Taiwan, R.O.C.

Tel: +886 4 2231 0059

Fax: +886 4 2236 0236

E-mail: die0824@ms14.hinet.net

URL <http://www.die-erste.com>